

## 9042 & 9442 SERIES LOCKING PULL DOOR PREP INSTRUCTIONS

### For Wood, Hollow Metal & Aluminum Doors

#### **VP9042-1 - Bolt Down**

Drill only the middle and bottom hole.

#### **VP9042-2 - Bolt Up**

Drill only the middle and top hole.  
Refer to your "Order Template" for the required distance between the middle and top hole.

#### **VP9442-1, VP9442-2, VP9442-3**

Drill all 3 holes. Refer to your "Order Template" for the required distance between the middle and top hole.

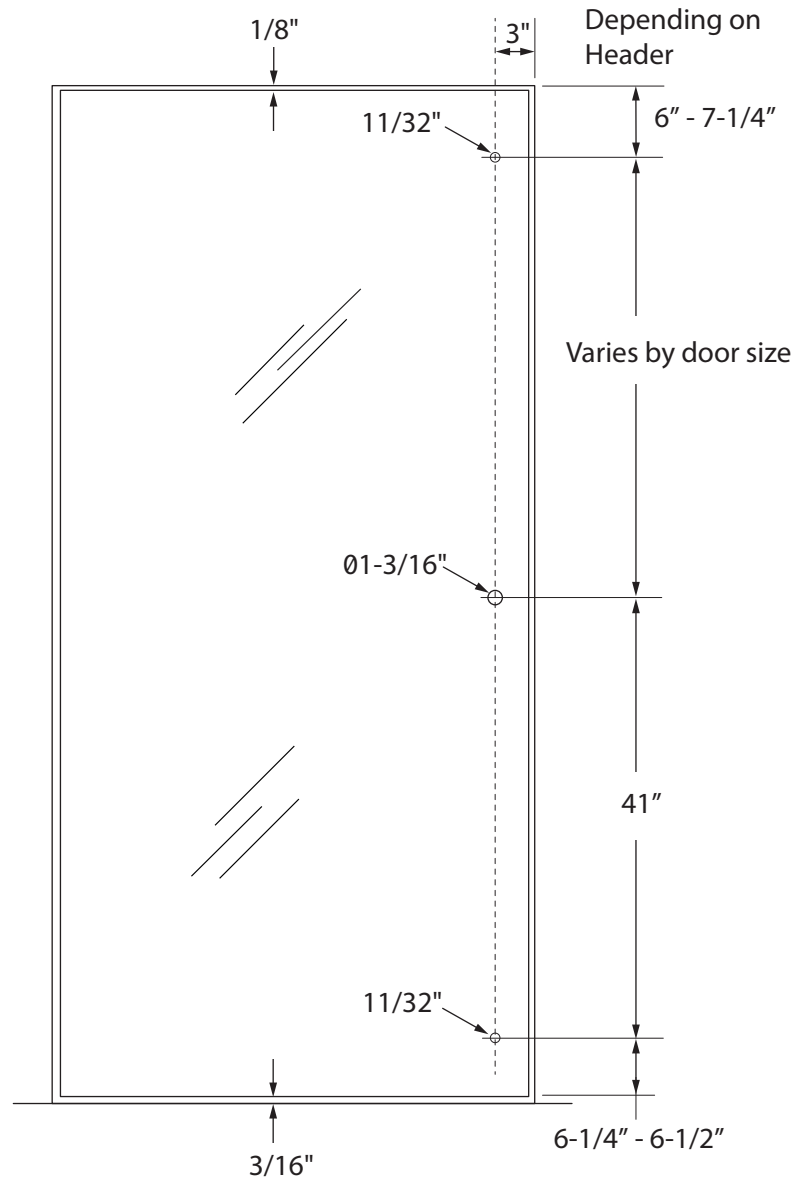

**Date: 12/17 - Rev. 1**